

# FX – FX DUAL

## FIRE TUBE STEAM BOILER

### Nominal pressure 5 bar



Image refers to the DUAL version with equipped floor kit

#### Standard equipment:

- steam accessory group for every generator, comprising:
  - steam stop valve for flow start
  - safety valve
  - level indicator with direct reflection
  - shut-off valve group and drain indicator
- monitoring instrumentation curve for every generator pressure, composed of:
  - 3 way test valve manometer
  - regulating pressure gauge
  - limit pressure gauge
  - PED approved manual retest safety pressure gage
- water delivery group for any generator, mounted on a boiler support, containing:
  - centrifugal pump suitable for 90°C water
  - delivery shut-off valve
  - pump suction filter
  - no return valve
- automatic purge group for each generator, composed of:
  - shut-off valve
  - pneumatic exhaust valve with compressed air electronic valve
- automatic conductivity probe level regulator for any generator, composed of:
  - pump start-up probe
  - pump shut-off probe
  - 1° alarm and burner block probe for low level
  - 2° alarm and burner block probe for low level
- boiler electric command panel, IP 54 electrical protection, composed of:
  - main switch
  - pump/main switch (off-manual-automatic)
  - burner switch
  - level regulation relay
  - low level 1° alarm relay with manual reset
  - low level 2° alarm relay with manual reset
  - high pressure light and alarm reset button
  - low level 1° pressure light and alarm reset button
  - low level 2° pressure light and alarm reset button
  - alarm siren

#### Main features

FX is an fully automatic, high efficiency, instantaneous steam boiler with smoke tubes and flame reversal,. Low water content and reduced dimensions are the prerogatives that make the FX generator the most indicated steam producer for all small and medium installations.

Some of the product's main features are related below:

- Single (FX) or modular operation boilers with two stacked boilers (FX DUAL)
- P265GH UNI EN 10028/2 and P275NH UNI EN 10028/3 quality steel boiler body welded and tested with methods approved and labeled CE in accordance with the PED 97 /23/EC directive
- horizontal wetback combustion chamber with flame reversal, supported and guided by a perforated stub to ensure its effective wetting
- flat tube plates with plasma cut holes
- plate containment with flanged PN 16 or PN 40 EN 1092-1 connections for equipment operation; equipped with lower inspection coupling
- P235GH UNI EN 10216/2 smoke tubes welded to tube plates, equipped with helical Turbolators
- single steel sheet front door, thermally insulated by ceramic fiber, mounted on adjustable hinges, easily opened by hand wheel. Without the need to remove the burner; equipped with light indicator for combustion control
- steel sheet rear smoke box can be removed using equipped bolts in order to clean the smoke tubes; provided with cleaning door and chimney connection
- compact dimension support (800 mm width) built in carbon steel plate adapted to equipment lift and handling by fork lift.
- high density mineral wool mattress thermal insulation of adequate thickness; Integral coating with stainless steel panels mounted on rectangular frame
- suitability for liquid or gaseous fuels, for a steam production from 50 to 300 kg/h
- Supplied accessories needed for automatic operation with mechanical and hydraulic assembly for all equipment and certifications, also in compliance with the PED 97 /23/EC Directive
- Electrical wiring converging to a single centralized control panel, having silicone insulated wires inserted in PVC protective sheaths all subjected to final functionality test

Available accessories	Code
FX Dual generator steam collector kit	96140150
FX and FX DUAL generator base Kit	96140100
FX and FX DUAL generator condensate separator kit	96140200
FX and FX DUAL generator double safety valve kit	96140060
FX and FX DUAL generator double level indicator kit	96140070
FX DUAL generator backup pump power delivery kit	96140090
FX and FX DUAL generator water delivery heating composed of electro valve and thermostat	96140050
FX and FX DUAL maximum level Kit	96140110

For each product always indicate the code at the time of the order.

# INDUSTRIAL RANGE

## STEAM FX

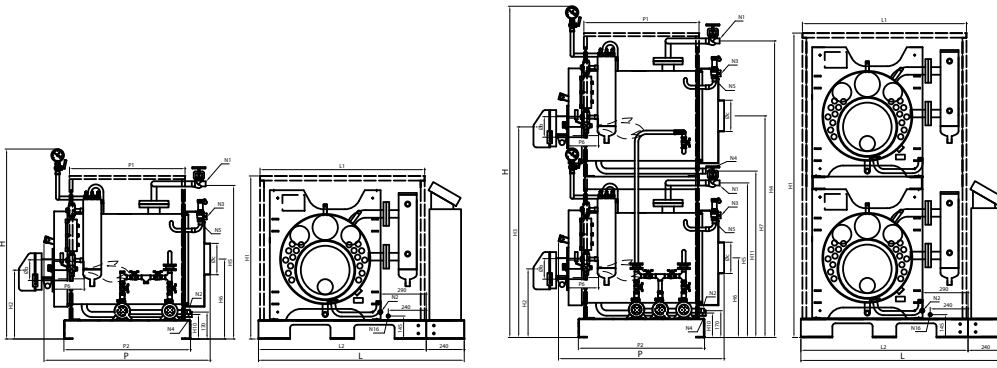

**FX - FX DUAL legend:**

- N1 Steam pressure
- N2 Power delivery
- N3 Safety valve drain
- N4 Boiler drain
- N5 Safety valve connection
- N16 Condensation chamber drain

Characteristics	Code product	Nominal Power kW	Flow Thermal kW	100% efficiency (ref. C.O.P.) %	Steam production* kg/h	Min-max work pressure bar	Volume level H <sub>2</sub> O lt	Total volume H <sub>2</sub> O lt	Fumes pressure drop mbar	Fuel consumption		Total weight kg
										Gas Nm <sup>3</sup> /h	Diesel fuel kg/h	
FX 50	86014055	31,7	34,8	91,09	50	3-4,5	50	59	0,4	3,6	2,9	430
FX 100	86014105	70,5	77,4	91,04	100	3-4,5	50	59	1,5	8	6,6	430
FX 150	86014155	104,6	115,0	91,12	150	3-4,5	50	59	3,2	11,9	9,8	430
FX 100 DUAL	86014103	63,4	69,6	91,09	100	3-4,5	100	118	0,4	7,1	5,9	830
FX 200 DUAL	86014205	141,0	154,9	91,04	200	3-4,5	100	118	1,5	15,8	13	830
FX 300 DUAL	86014305	209,2	230,0	91,12	300	3-4,5	100	118	3,2	23,8	19,6	830

Dimensions	H	H1	H2	H3	H4	H5	H6	H7	H10	H11	L	L1	L2	P	P1	P2	P6	Øb	Øc	N1	N2	N3	N4	N5	N16
Model	mm	mm	mm	mm	mm	mm	mm	mm	mm	mm	mm	mm	mm	mm	mm	mm	mm	mm	mm	DN/in	DN/in	DN/in	DN/in	DN/in	DN/in
FX 50	1200	1030	435	-	-	980	505	-	155	-	1300	1040	1060	1050	730	800	150-200	130	200	1"	3/4"	1"	1"	1/2"	1/2"
FX 100	1200	1030	435	-	-	980	505	-	155	-	1300	1040	1060	1050	730	800	150-200	130	200	1"	3/4"	1"	1"	1/2"	1/2"
FX 150	1200	1030	435	-	-	980	505	-	155	-	1300	1040	1060	1050	730	800	150-200	130	200	1"	3/4"	1"	1"	1/2"	1/2"
FX 100 DUAL	2100	1930	435	1335	1880	980	505	1405	155	1055	1300	1040	1060	1050	730	800	150-200	130	200	1"	3/4"	1"	1"	1/2"	1/2"
FX 200 DUAL	2100	1930	435	1335	1880	980	505	1405	155	1055	1300	1040	1060	1050	730	800	150-200	130	200	1"	3/4"	1"	1"	1/2"	1/2"
FX 300 DUAL	2100	1930	435	1335	1880	980	505	1405	155	1055	1300	1040	1060	1050	730	800	150-200	130	200	1"	3/4"	1"	1"	1/2"	1/2"

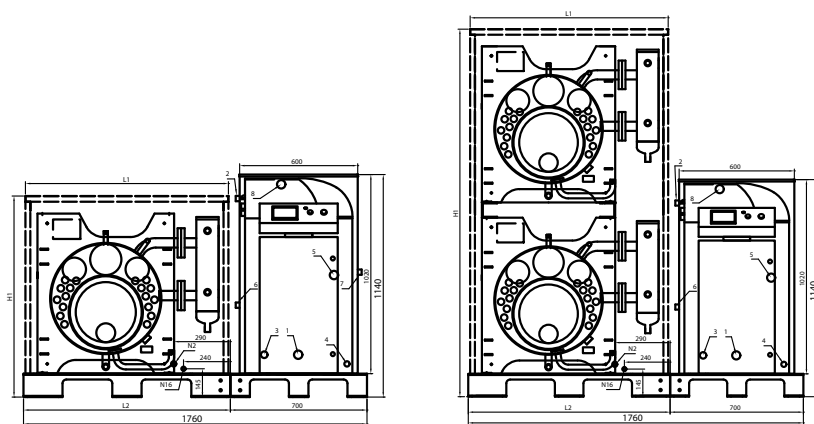

**FX - FX DUAL legend:**

**with water softener and condensate collection vessel:**

- 1 1" steam input
- 2 1/2" water input
- 3 3/4" pump output
- 4 1/2" drain
- 6 1/2" minimum level shut-off
- 7 1/2" thermostat
- 8 1" vent/overflow

\* production with at least 80°C water